

Mini Door Contact (MDC-3) User Manual

The Mini Door Contact monitors the opening/closing of specified devices (e.g. door or window). The Door Contact is fixed to the monitored device frame with an actuating magnet fixed to the device. When the door or window opens, the magnet moves away from the Door Contact, activating an internal magnetic switch causing the Door Contact to transmit alarm signal to the Control Panel. The device also has the capabilities of communicating signal problems along with low battery situations.

The Door Contact design is consisted of a front cover and a back cover. The front cover(back) contains all electronics and the back cover provides a means for fixing the device. An enclosed PCB tamper switch provides tamper protection against unauthorized device opening.

Identifying the parts

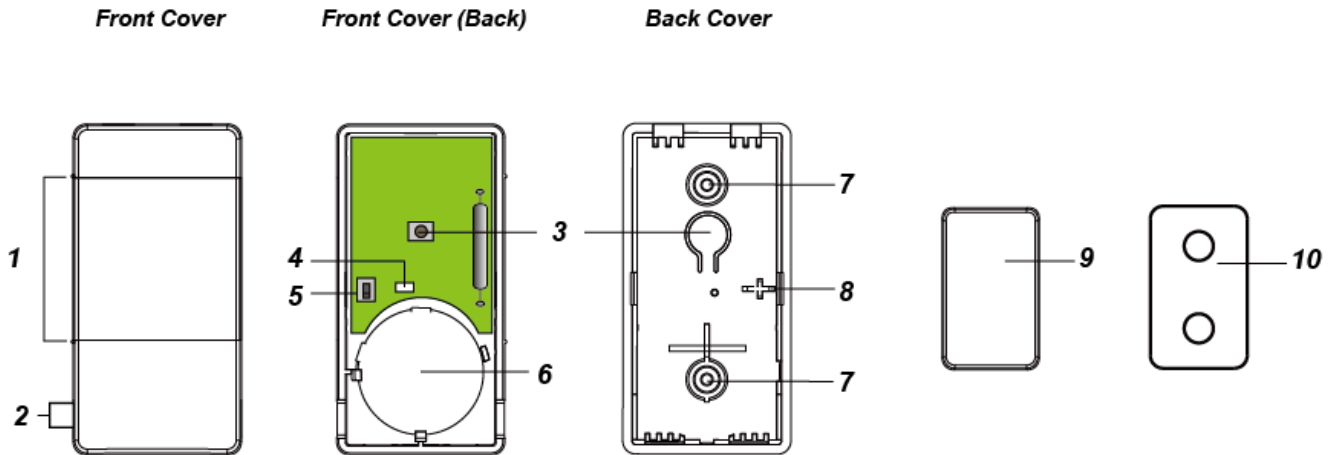

1. Rib Marks
2. Battery Insulator
3. Learn / Test Button
 - Press the Test button to transmit a learn code.
 - Press the Test button once to enter Test Mode for 3 minutes.
4. Red LED Indicator
5. Tamper Switch
6. Battery
7. Mounting Holes (Knockouts)
8. Tamper Compression Mark
9. Magnet
10. Magnet Spacer

● Accessories Included

- a) 1 Magnet
- b) 1 double-sided adhesive Magnet Spacer
- c) 2 Screws
- d) 4 Wall Plugs
- e) 1 double-sided adhesive Velcro tape (for Door Contact)
- f) 1 double-sided adhesive tape pad (for Magnet)
- g) 2 Magnet mounting screws

Features

● LED Indicator

In Normal operation mode, the LED indicator remains off except in the following situations:

- When Door Contact's Tamper switch is triggered.
- When the Door Contact is activated with either Tamper or Low battery condition.
- When the Door Contact is activated and transmitting the signal under the Test mode.

● Supervision

- The Door Contact will automatically transmit Supervisory signals periodically to the Control Panel at random intervals of 30 to 50 minutes in Normal Operation Mode.
- If the Control Panel has not received the signal from the Door Contact for a preset period of time, the Control Panel will indicate that particular Door Contact is experiencing an out-of-signal problem.

- **Tamper Switch**

- The tamper switch is designed to protect against unauthorized cover opening. When the tamper is triggered, Door Contact will emit a signal to the Control Panel for reporting, the LED will also light up.

- **Battery**

The MDC-3 uses one **3V CR2450 Lithium battery** as its power source. The Door Contact is also capable of detecting low battery. When the battery is low, a low battery signal will be sent to the Control Panel along with regular transmission. The LED will light up when the Door Contact is activated under low battery status.

- **Changing Battery**

You need to open the cover to insert/remove the battery

Step 1. Use a flat-headed screwdriver to fit into the cover opening hole on one side as **(Pic1)**.

Step 2. Push the flat-headed screwdriver upwards as **(Pic2)**.

Step 3. Turn to the other side and repeat Step 1 and Step 2.

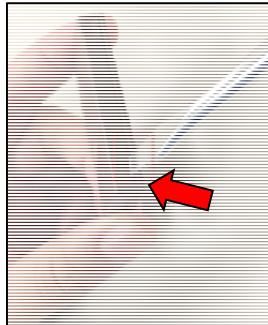

(Pic 1)

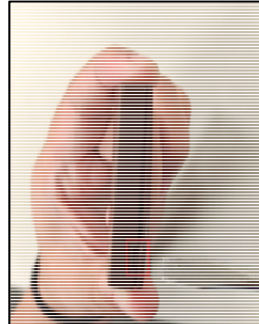

(Pic 2)

Step 4. Once the cover is opened, you can proceed to change the battery.

Step 5. After the battery has been removed, press the Learn / Test button 5-6 times to fully discharge before inserting the new battery.

<NOTE>

- ☞ Make sure the battery mark with the positive side (+) is faced upwards when inserting the battery.
- ☞ Make sure to insert or place the battery from the top right angle as indicated in the picture. **(Pic3)**

Step 5. To replace the cover:

- Make sure the Tamper Compression Mark is aimed at the Tamper Switch **(Pic 4)**

(Pic 3)

- Also make sure the bottom hooks of the back cover is latched on the bottom of the front cover (back) as **(Pic 5)**
- Fit the bottom hooks into the bottom latches of the front cover (back) then push it downwards as (1) in **(Pic 6)** then push forward (2) the entire back cover to close it until you hear a clip sound.

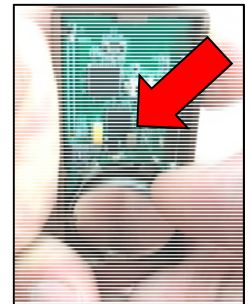

(Pic 4)



(Pic 5)

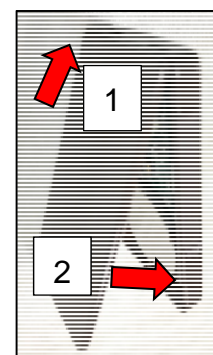

(Pic 6)

- **Test Mode**

- The Door Contact can be put into Test mode for 3 minutes by pressing the Test Button once.
- Under Test Mode, the LED will light up whenever the Door Contact is activated.
- Each additional Test Button press will reset Test Mode time to 3 minutes.

- **Getting Started**

Step 1: Remove the battery insulator of the Door Contact.

Step 2: Put the Control Panel into learning mode, refer to Control Panel manual for detail.

Step 3: Press the Learn/Test Button on Door Contact to send signal to the Control Panel.

Step 4: If the Control Panel successfully receives the signal, the Control Panel should respond (e.g. emitting beeps). Refer to your Control Panel manual to complete the learning process.

Step 5: After the Door Contact is learnt-in, put the Control Panel into **"Walk Test"** mode, hold the Door Contact at the desired location, and press the Test button to confirm if this location is within signal range of the Control Panel.

Step 6: When you are satisfied with the Door Contact at the chosen location, proceed to **installation**.

Installation

● **Mounting Methods**

- Mount the Door Contact on the fixed frame of door/window using **Velcro tape Mounting** or **Screw Mounting**.
- Mount the magnet on the mobile object (door/window) using **Screw Mounting** or **Adhesive Mounting**.
- Align the magnet according to the rib mark on Door Contact. Where required, use the Magnet Spacer to better align the magnet to the rib marks.

< NOTE >

☞ The magnet should be no more than **15mm** from the detector when the door is closed.

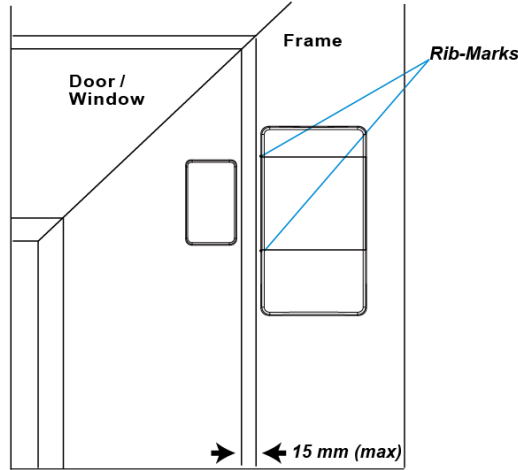

Mounting Methods for the Door Contact

● **Screw Mounting**

The back cover has two Mounting Holes (knockouts), where the plastic is thinner, for mounting purpose.

To mount the Door Contact:

- I. Remove the cover.
- II. Break through the knockout on the back cover.
- III. Using the holes as a template, drill both holes.
- IV. Insert wall plugs if fixing into plaster or brick.
- V. Screw the back cover into the wall plug using a Philips screwdriver.
- VI. Attach the front cover to the back cover.

● **Velcro tape Mounting:**

The Door Contact can be wall mounted using Velcro tape provided.

- I. Clean the wall mounting location and back of the Door Contact with degreaser. Do not mount on wall with cracking paint or rough surface.
- II. The Velcro tape can be separated to Hook and Loop side. **(Pic 7)**
- III. Remove the protective cover of the Hook side and attach to the back of the Door Contact. Press firmly for 30 seconds to ensure good contact. **(Pic 8.)**
- IV. Remove the protective cover of the Loop side and apply to desired mounting location as in **(Pic 9.)** Press firmly for 30 seconds to ensure good contact.
- V. Apply the Door Contact on the Loop side Velcro taped on the wall **(Pic 10 & 11.)**

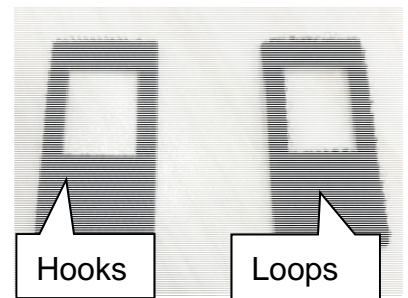

(Pic 7.)



(Pic 8.)



(Pic 9.)



(Pic 10.)



(Pic 11.)

Mounting Methods for the Magnet

● **Screw Mounting**

The back cover of the magnet has two Mounting Holes for mounting purpose.

To mount the Magnet:

- I. Open the back cover by using a flat-headed screwdriver to fit into the caved in area and push upwards.



- II. Using the holes as a template, drill both holes.

III. Screw the back cover into the door/window using a Philips screwdriver. Where required, use the Magnet Spacer to better align the magnet to the rib marks.

- IV. Attach the front cover to the back cover. You will hear a Click sound when the front cover is stabilized onto the back cover..

Screw Mount with Spacer

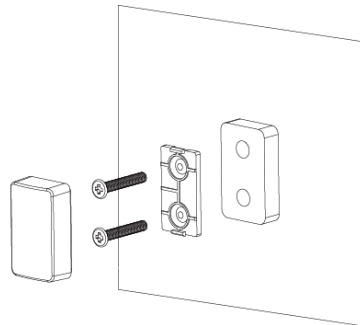

Screw Mount without Spacer

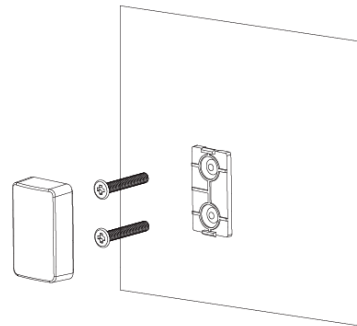

● **Adhesive Mounting**

The Magnet can also be mounted using the double-sided adhesive tape pad or the double-sided adhesive Magnet Spacer.

- I. Clean the mounting location and back of the Magnet with a suitable degreaser.
- II. Remove the protective covering from one side of the double-sided adhesive pad or the double-sided adhesive Magnet Spacer. Apply to the back of the Magnet and press firmly for 30 seconds to ensure good contact.
- III. Remove the other cover and firmly press the Magnet onto the desired location for 30 seconds..

Adhesive Mount with Spacer

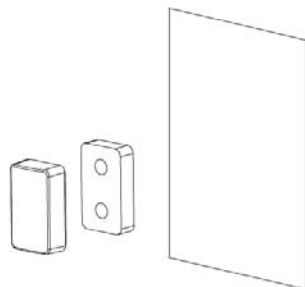

Adhesive Mount with Pad

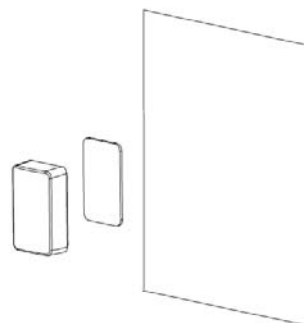

<NOTE>

- I. Please do not re-apply the double-sided adhesive tape pad or the double-sided adhesive Magnet Spacer. They cannot be reused